

SUPER

AFC

SUPER AIR FLOW CONVERTER

INSTRUCTION MANUAL

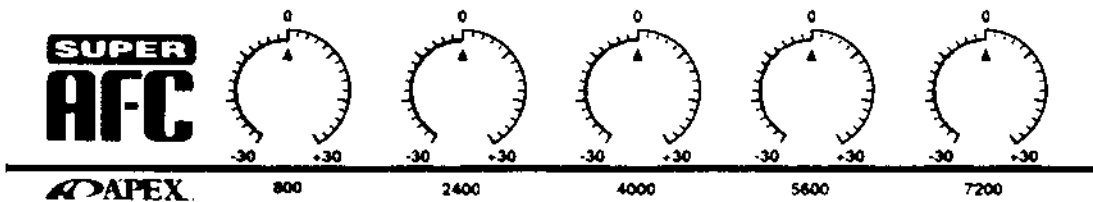

APEXⁱ

Table of Contents

❶ Preface	1
❷ Parts List	1
❸ Part Names	2
❹ For the Installer.....	2
❺ Feature Explanation.....	4
❻ Vehicle Specific Setting Table	6
❼ Vehicle Specific ECU Wiring Diagram	10
❽ Connection Diagram for S-AFC and Other Equipment	14

1

Preface

Thank you for purchasing the APEXi Super AFC (Super Air Flow Converter.) This unit is a highly efficient controller allowing the vehicle air flow sensor signal to be easily adjusted.

The air flow sensor measures the amount of intake air and allows the vehicle engine control unit (computer) to specify the fuel settings for the vehicle. This unit allows this signal to be adjusted so that it becomes possible to change the fuel setting amounts for the vehicle.











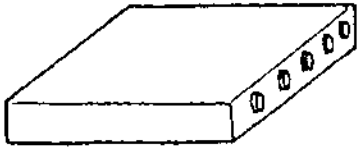

CAUTION

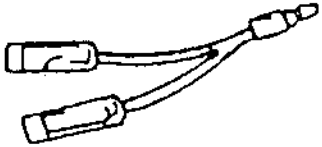
- *This unit may not be used on any vehicle that is not listed on the vehicle specific setting table.
- *Please do not use this unit for any other purposes than the ones stated above.

2

Parts List

1. Control Unit1 	6. Male Sleeve2 
2. Signal Harness2 	7. Female Sleeve2 
3. Splitting Adapter Harness1 	8. Splitting cap3 
4. Male Fitting2 	9. Instruction Manual1 
5. Female Fitting2 	10. Double-sided Tape1 

3

Part Names

Front Face

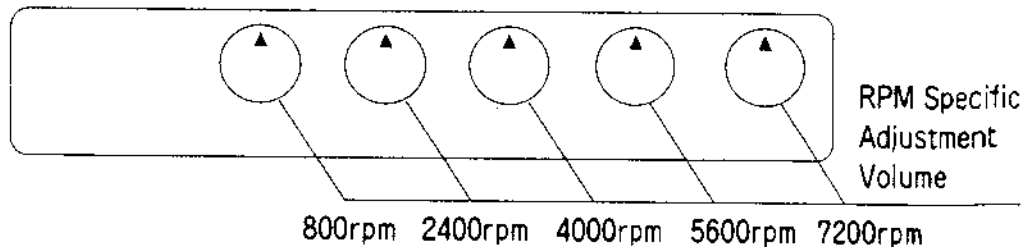

Back Face

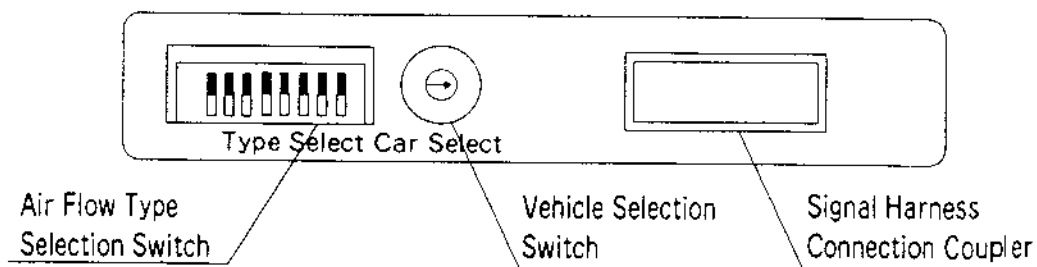

4

For The Installer



WARNING

- *Be sure to disconnect the negative terminal of the battery before starting the installation procedures.
- *Please mount the control unit in a position where the driver of the vehicle can not adjust the unit while driving.
-(At least 50cm or farther from the driver.)

[1] Begin with the Wiring

1. Disconnect the negative terminal of the battery
 2. Use the ECU location line of the Vehicle Specific Setting Table and the Vehicle Specific ECU Wiring Diagram on page 13 to locate the vehicle engine control unit (ECU.)
 3. While referring to the Vehicle Specific ECU Wiring Diagram, cut the air flow signal wire of the harness going into the engine control unit and put a fitting on the wire. -Use a Male Fitting for the engine control unit side and use a Female Fitting for the vehicle harness side.
- *Vehicles with RB26DETT engine have 2 air flow signal wires so be sure to cut both air flow signal wires.
4. While referring to the Vehicle Specific ECU Wiring Diagram, use the splitting cap to connect the power wire, ground wire, and rpm signal wire of the engine control unit harness to the red, black, and green wires of the included harness. Be sure to wrap all connections with electrical tape.

5. connect the white wire of the signal harness to the Female Fitting used in 3. and connect the yellow wire to the Male Fitting.
6. Reconnect the negative terminal of the battery to complete the installation procedures.

Connection of the Fittings

Strip 5mm of the outer cover

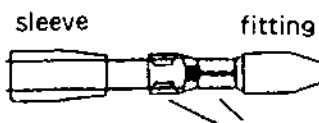

be sure to have a secure connection

How to Use the Splitting Tap

1. Remove 3mm off the connection wire



2. Remove 5mm off the included wire



3. Twist the two wires together



4. Secure with the tap over the two wires



*Be sure to cover the secured tap with electrical tape

Wiring Diagram

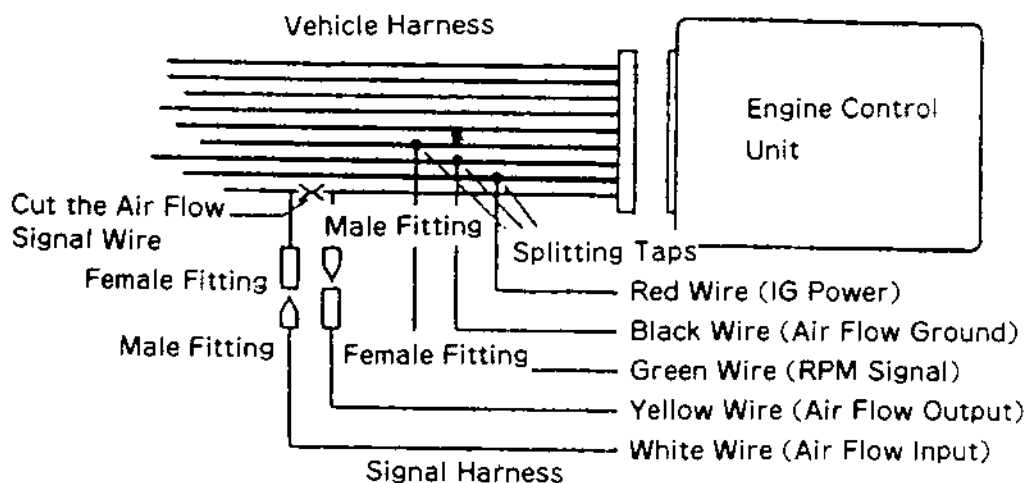

*Please use the diagram below for vehicles using the RB26DET engine.

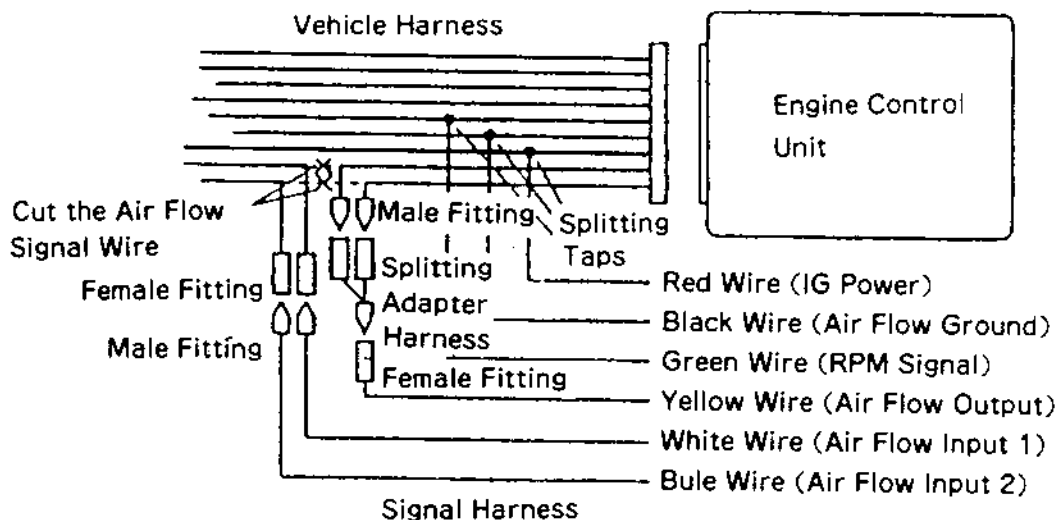

[2] Please refer to the Vehicle Specific Setting Table to set the Vehicle Selection Switch and Air Flow Type Selection Switch on the back side of the unit.

Setting the Air Flow Type Selection Switch.

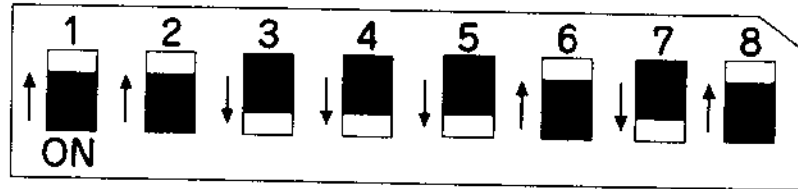

ex. INFINITI Q45

Type Select

※Please move the switch towards the white colored section.

[3] Once the engine has been started, it is now possible to adjust the air flow signal by adjusting the RPM Specific Adjustment Volume.

5 Explanation of Function

This unit takes the input air flow sensor signal and modifies the signal to show volumes of air which can be controlled by adjusting the RPM Specific Adjustment Volume on the front of the unit. The unit then translates the newly adjusted air volume amount to the corresponding air flow sensor signal and sends the information to the engine control unit. For example, the adjustment volume is in the +15% position. If a 100% air flow signal input is being received at this point, the output from this unit will be 115% to the engine control unit allowing the injectors to spray fuel amounts for 115% air flow signal.

Because the engine control unit calculates optimum fuel amounts according to air flow signal input, the air flow volume and fuel amounts will remain almost perfectly proportional. The next diagram depicts a +15% fuel increase.

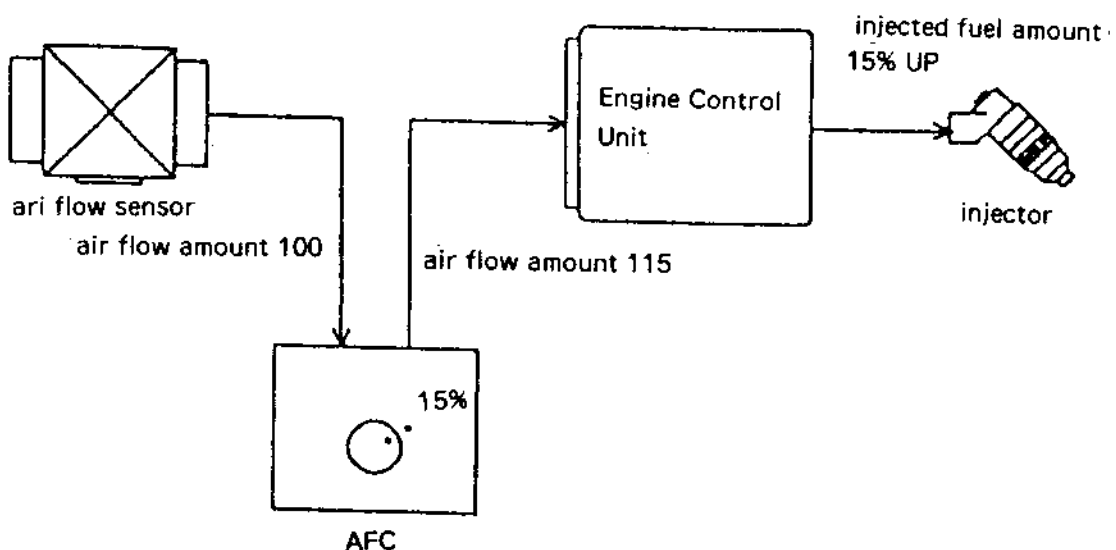

With the S-AFC, the air flow signal may be adjusted according to specific RPM ranges by using the 5 adjusting volumes on the front of the unit. The RPM ranges include 800, 2400, 4000, 5600, 7200 with a maximum air flow adjustment of + or -30% in 2% increments. Adjusting each of the volume knobs on the front of the unit will allow setting of the RPM ranges.

EX. When the volumes are set in the positions below

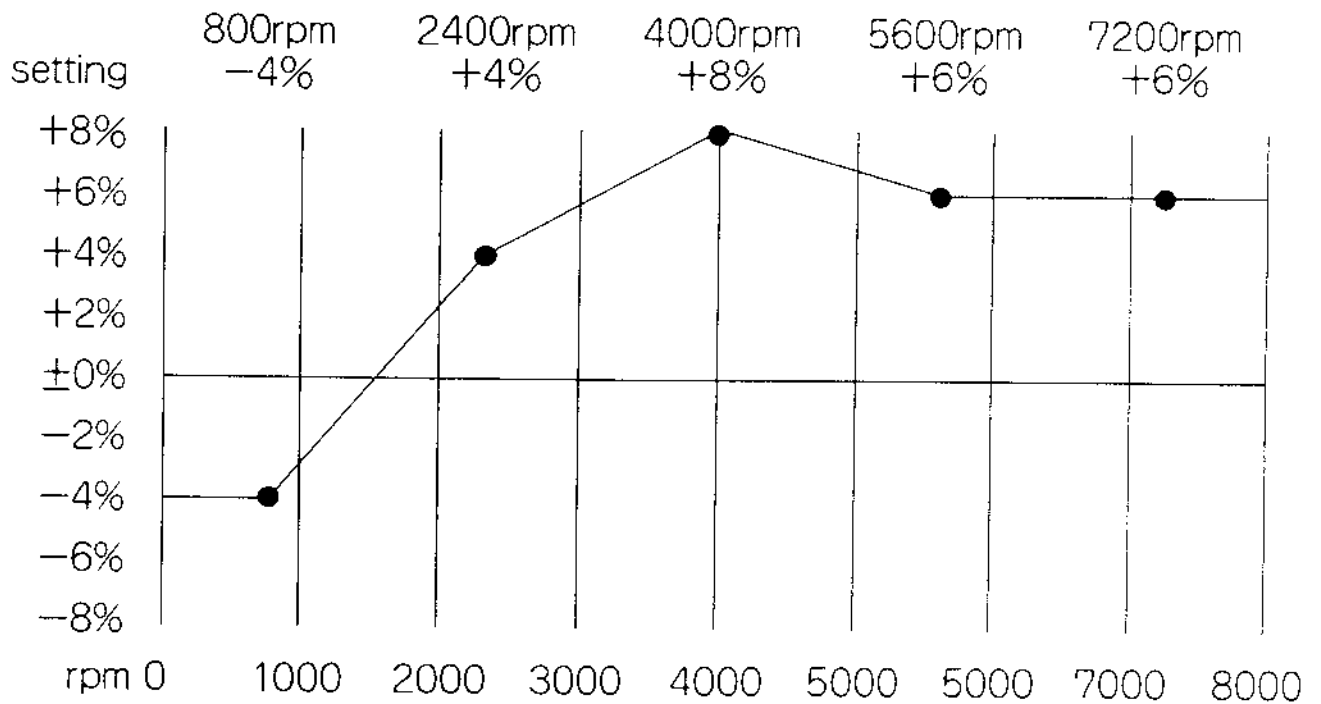

6

Vehicle Specific Setting Table

Please refer to the Vehicle Specific Setting Table to set the Vehicle Selection Switch and Air Flow Type Selection Switch on the back side of the unit.

Setting the Air Flow Type Selection Switch.

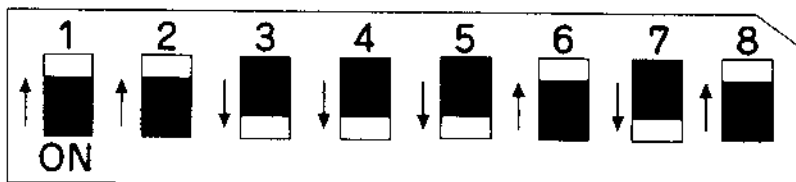

ex. INFINITI Q45

Type Select

※Please Move the Switch Towards the Colored Section.

6.1 NISSAN

Vehicle Name	Model Type	Engine	Year	ECU Location	Type Select SW	Car Sel	ECU Wiring Diagram	
PRESIDENT	G50	VH45DE	'90.10~	a		1	N1	
INFINITE Q45	G50	VH45DE	'89.10~	a		1	N1	
CIMA III	FGY33	VH41DE	'96. 6~	a		1	N11	
	FHY33	VQ30DET				4	N5	
CIMA II	FGY32	VH41DE	'91. 8~'96. 6	a		1	N1	
	FPY32	VG30DET	'93. 9~'96. 6			4		
CIMA I	FPY31	VG30DET	'89. 8~'91. 7	a		4	N1	
		VG30DE	'88. 1~'89. 7				N10	
		VG30DET						
		VG30DE						
FAIRLADY Z	Z32	VG30DETT	'89. 7~	c		2	N1	
		VG30DET						
LEOPARD	Y33	VQ30DET	'96. 3~	a		4	N5	
		VQ30DE						
LEOPARD J FERRY	JGBY32	VH41DE	'92. 6~'96. 3	a		1	N1	
	JPY32	VG30DE				4		
LEOPARD	UF31	VG30DET	'88. 8~'92. 6	a		4	N1	
		VG30DE					N10	
	GF31	VG20DET						
CEDRIC GLORIA	Y33	VQ30DET	'95. 6~	a		4	N5	
		VQ30DE						
	Y32	VG30DET	'91. 6~'95. 6	a		4	N1	
		VG30DE						
	Y31	VG20DET	'89. 6~'91. 6	a		4	N1	
		VG20DE						
CEFIRO	A32	VQ30DE	'94. 8~	e		4	N1	
		VQ25DE						
		VQ20DE						
	A31	RB20DET	'88. 9~'94. 8	a		4	N1	
		RB25DE	'92. 5~'94. 8					
		RB20DE	'88. 9~'94. 8					
LAUREL	C34	RB25DET	'94. 1~	a		4	N1	
		RB25DE						'93. 1~
		RB20DE						
	C33	RB25DE	'91.10~'93. 1	a		4	N1	
		RB20DET	'89. 1~'93. 1					
		RB20DE						

*These Vehicle Names Are Usable only in Japan.

Vehicle Name	Model Type	Engine	Year	ECU Location	Type Select SW	Car Sel	ECU Wiring Diagram
SKYLINE	R33	RB26DETT	'95. 1~	a		B	N2
		RB25DET	'93. 8~			4	N1
		RB25DE					
	R32	RB26DETT	'89. 8~'95. 1	a		B	N2
		RB25DE	'91. 8~'93. 8			4	N1
		RB20DET	'89. 5~'93. 8				
		RB20DE					
R31	RB20DET	'87. 9~'89. 5	a		4	N6	
BLUE BIRD	U31	SR20DET	'91. 9~'96. 1	e		6	N3
		SR20DE					
		SR18DE					
	U12	SR20DET	'89.10~'91. 9	e		6	N3
		SR20DE					
		CA18DET	'87. 9~'89.10			7	N1
		CA18DE					
SILVIA	S14	SR20DET	'96. 6~	a		5	N3
			'93.10~'96. 6				N1
		SR20DE	'93.10~				N3
	PS13	SR20DET	'91. 1~'93.10	a		6	N9
		SR20DE					N3
	S13	CA18DET	'88. 5~'91. 1	a		7	N1
CA18DE							
180SX	RPS13	SR20DET	'91. 1~	a		6	N9
	RS13	CA18DET	'89. 3~'91. 1			7	N1
PULSAR	N14	SR20DET	'90. 8~'95. 1	e		5	N3
		SR18DE					
PRIMERA	P10	SR20DE	'90. 2~'95. 9	e		6	N3
		SR18DE	'92. 9~'95. 9				
AVENEIR	W10	SR20DET	'95. 8~	e		6	N3
		SR20DE	'90. 5~				
		SR18DE	'93. 1~				
PRESEA	R10	SR20DE	'90. 6~'95. 1	e		6	N3
		SR18DE	'92. 6~'95. 1				
SUNNY	B14	SR18DE	'94. 1~	e		6	N3
	B13	SR18DE	'90. 1~'94. 1	e			N3
NX CORPE	B13	SR18DE	'90. 1~	e		6	N3
MARCH	K11	CG13DE	'92. 1~	a		9	N4
		CG10DE					
TERRANO	YD21	VG30E	'89.10~'95. 8	f		6	N3

*These Vehicle Names Are Usable only in Japan.

6.2 TOYOTA

Vehicle Name	Model Type	Engine	Year	ECU Location	Type Select SW	Car Sel	ECU Wiring Diagram	
CELSIOR	UCF10	1UZ-FE	'92. 8~'94. 9	d		0	T2	
			'89.10~'92. 8				T1	
CROWN MAJESTA	UZS14#	1UZ-FE	'91.10~'95. 8	c		0	T3	
	JZS14#	2JZ-GE					3	T4
ARISTO	UZS143	1UZ-FE	'92.10~	c		0	T3	
	JZS147	2JZ-GTE	'91.10~				1	T17
		2JZ-GE					3	T4
SUPRA	JZA80	2JZ-GTE	'93. 5~	c		1	T17	
		2JZ-GE					3	T4
	JZA70	1JZ-GTE	'90. 8~'93. 4	d		1	T5	
	MA70	7M-GTE	'88. 8~'90. 7				0	T6
			'86. 2~'88. 8				1	Tubor A T14
	'88. 8~	3	T13					
	GA70	1G-GE	'88. 8~'93. 4	3	T12			
SOARER	UZZ31	1UZ-FE	'91. 5~	c		0	T3	
	JZZ31	2JZ-GE	'94. 1~				3	T18
	JZZ30	1JZ-GTE	'91. 5~				1	
	MZ20	7M-GTE	'88. 1~'91. 4	d		0	T6	
	GZ20	1G-GE	'86. 1~'88. 1				3	T7
			'89. 1~'91. 4				3	T13
'86. 1~'88.12	3	T12						
MARK II CRESTA CHASER	JZX91	2JZ-GE	'92.10~	e		3	T18	
	JZX90	1JZ-GTE						1
		1JZ-GE						3
	JZX81	1JZ-GTE	'90. 8~'92. 9	d		1	T5	
	1JZ-GE	3						
GX81	1G-GE	'88. 8~'92. 9	3	T13				
MR2	SW20	3S-GTE	'93.10~	Rear Trunk		2	T13	
	Late Model	3S-GE					3	T5
	Early Model	3S-GE					'89.10~'93.10	3
	AW11	4A-GE	'84. 6~'89. 9	Trunk		3	T9	
CELICA	ST205	3S-GTE	'94. 2~	Rear Trunk		2	T13	
	ST202	3S-GE	'93.10~	e		3	T5	
		3S-FE	'96. 6~				MT T15	
		3S-FE	'93.10~'96. 6				AT T16	
	ST182	3S-GE	'89.10~'93. 9	e		3	T13	
CURREN	ST206	3S-GE	'94. 1~	e		3	T5	
		3S-FE	'96. 6~				MT T15	
							AT T16	
		'95.10~'96. 6	MT T10					
	'94. 1~'95.10	W.O/TRC T13						
		W/TRC T5						
		W.O/TRC T13						
W/TRC T5								
CARINA ED CORONA EXIV	ST202	3S-GE	'93.10~	e		3	T5	
		3S-FE					W.O/TRC T13	
CALDINA	ST191	3S-GE	'92.11~	e		3	2WD T19	
	ST195	3S-FE					4WD MT T10	
							4WD AT T13	

















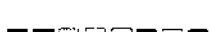

*These Vehicle Names Are Usable only in Japan.

Vehicle Name	Model Type	Engine	Year	ECU Location	Type Select SW	Car Sel	ECU Wiring Diagram
COROLLA SPRINTER LEVIN TRUENO	AE111	4A-GE	'95. 5~	e		3	T13
		4A-FE					T10
		5A-FE					
	AE101	4A-GZE	'91. 6~'95. 5	e		1	T13
		4A-FE					MT T10 AT T13
	AE92	4A-GZE	'89. 5~'91. 5	e		1	T13
'89. 5~'91. 5			3				T10
'87. 5~'89. 5			T9				
AE86	4A-GE	'83. 5~'87. 4	a		3	T9	
COROLLA CERES SPRINTER MARINO	AE111	4A-GE	'95. 5~	e		3	T13
		4A-FE					T10
		5A-FE					
AE101	4A-FE	'92. 5~'95. 5	e		3	MT T10 AT T13	
COROLLA FX	AE101	4A-FE	'92. 5~'95. 5	e		3	MT T10 AT T13
							AE92
		'87. 5~'89. 5			T9		
STARLET	EP91	4E-FTE	'95.12~	c		1	T10
		4E-FE					3
	EP82	4E-FTE	'89.12~'95.12	e		1	MT T11
			'92. 1~'95.12				AT T10
			'89.12~'92. 1				AT T11
	4E-FE	'89.12~'95.12	3	T11			
EP71	2E-TE	'86. 1~'89.12	e		1	3	T9
	2E-E						
RAV4	SXA10G	3S-FE	'94. 5~	e		3	MT T10 AT T13

*These Vehicle Names Are Usable only in Japan.















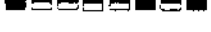



*Air Flow Meter Can Not Correspond Flap Type.

6.3 MITSUBISHI

Vehicle Name	Model Type	Engine	Year	ECU Location	Type Select SW	Car Sel	ECU Wiring Diagram
DIAMANTE	F36A	6G72 MIV	'95. 1~	e		5	M6
		6G72				0	M2
	F17A	6G72	'90. 5~'94.12	a		0	M3
GTO	Z16A	6G72	'90.10~	The back of radio		0	M3
GALANT	E84A	6A12	'92. 5~	e		0	M3
	E39A	4G63	'87.10~'92. 4	b		0	M4
ECLIPSE	D32A	4G63	'95. 6~	The back of radio		0	M1
	D27A	4G63	'90. 2~	The back of radio		0	M4
LANCER	CM5A	4G93	'95.10~	b		0	M1
	CK4A	4G92 MIV				5	M6
	CE9A	4G63	'93.10~'95.10		0	M3	
	CD9A	4G63	'92.10~'93.10		0		
	CD5A	4G93	'91.10~'95.10		0		
FTO	DE3A	6A12 MIV	'94.10~	b		5	M6
		6A12				0	M3
	DE2A	4G93				0	M1
PAJERO	V25W	6G74	'93. 7~	a		0	M3
	V23W	6G72	'91. 1~			0	M5
RVR	N23W	4G63	'92.10~	b		0	M3

*MIV=MIVEC

6.4 HONDA

Vehicle Name	Model Type	Engine	Year	ECU Location	Type Select SW	Car Sel	ECU Wiring Diagram
NSX	NA1	C30A	'90. 9~	The back of driver's seat		6	H1
LEGEND	KA9	C35A	'96. 2~	c		6	H1
	KA7	C32A	'90.10~'96. 2	c		6	H1
	KA8		'90.12~'96. 2				
INSPIRE	UA2	G25A	'95. 2~	c		6	H2
	UA1	G20A					
	CC2	G25A	'92. 1~'95. 2	c		6	H2
	CB5	G20A	'89.10~'92. 1	c		6	H2
PRELUDE	BB1	H22A	'91. 9~	c		6	W/TRC H2
	BB4						W/O TRC H3
ACCORD	CD6	H22A	'93. 9~	c		6	H3
	CD5	F22B					H3
ACCORD WAGON	CE1	F22B	'94. 3~	c		6	H3
	CB9	F22A	'91. 3~'94. 3	c		6	H4
INTEGRA	CD2	B18C	'95. 9~	a		6	MT H6
			'93. 5~'95. 9				AT H2
	DA6	B16A	'89. 4~'93. 5	c		6	H5
							D15B
CIVIC	EK4	B16A	'95. 9~	a		6	H6
	EK3	D15B					
	EG6	B16A	'91. 9~'95. 9	a		6	H3
	EG4	D15B					
CR-X	EF9	B16A	'89. 9~'91. 9	c		6	H5
	EG2	B16A	'92. 3~	a		6	H3
		EG1					
CR-V	EF8	B16A	'89. 9~'92. 3	c		6	H5
CR-V	RD-1	B20B	'95.10~	a		6	H2
ODYSSEY	RA-1	F22B	'94.10~	c		6	H3
	RA-2						

*These Vehicle Names Are Usable only in Japan.

6.5 MAZDA

Vehicle Name	Model Type	Engine	Year	ECU Location	Type Select SW	Car Sel	ECU Wiring Diagram
RX-7	FD3S	13B-REW	'91. 1	a		4	Z5
			'91.12~'95.12				Z1
ROAD STER	NA8C	BP-ZE	'95. 8	c		D	Z6
			'93. 8~'95. 8				Z4

*These Vehicle Names Are Usable only in Japan.

*Air Flow Meter Can Not Correspond Flap Type.

6.6 SUBARU

Vehicle Name	Model Type	Engine	Year	ECU Location	Type Select SW	Car Sel	ECU Wiring Diagram	
LEGACY	BD5	EJ20H	'93.10~'96. 6	c		4	F1	
	BG5							
	BD5	EJ20D					F3	
	BG5							
	BG9	EJ25D	'94.10~'96. 6					
	BG5	EJ20G	'89. 2~'93.10				h	F2
IMPREZA	GC8	EJ20G	'92.11~	c		A	F2	
	GF8		'93.10~					

6.7 ISUZU

Vehicle Name	Model Type	Engine	Year	ECU Location	Type Select SW	Car Sel	ECU Wiring Diagram
BIG HORN	UBS25	6VD1	'91.12~	e		7	I1

6.8 SUZUKI

Vehicle Name	Model Type	Engine	Year	ECU Location	Type Select SW	Car Sel	ECU Wiring Diagram
ALTO WORKS	HA21S	K6A T. C	'94.11~	d		8	S1
	HB21S	DOHC					MT S2
	HA11S	F6A T. C					AT S3
	HB11S	SOHC					
CAPUCHINO	EA21R	K6A	'95. 5~	k		8	S4
	EA11R	F6A	'91.11~'95. 5	p			S5
WAGON-R	CT21S	F6A T. C	'95.11~	b		8	MT S2
	CV21S						AT S3
	CT21S	F6A T. C	'93. 9~'95.11	b		8	MT S5
	CV21S						AT S3

6.9 DAIHATSU

Vehicle Name	Model Type	Engine	Year	ECU Location	Type Select SW	Car Sel	ECU Wiring Diagram
MIRA TR-XX	L502S	JB-JL	'94. 9~	d		8	D1
	L512S						
MOVE	L602S	JB-JL	'95. 8~	d		8	D1

*These Vehicle Names Are Usable only in Japan.

●Abbreviations

TRC.....Traction Control

A/T.....Automatic Transmission

M/T.....Mannual Transmission

T/C.....Torbo Charger

S/C.....Super Charger

N/A.....Natural Aspiration

2WD.....2 Wheels Drive

4WD.....4 Wheels Drive

7

Vehicle Specific ECU Wiring Diagram

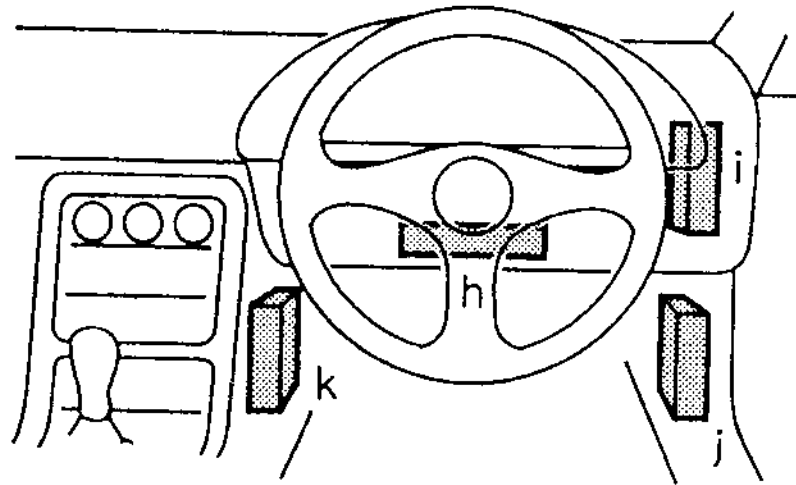
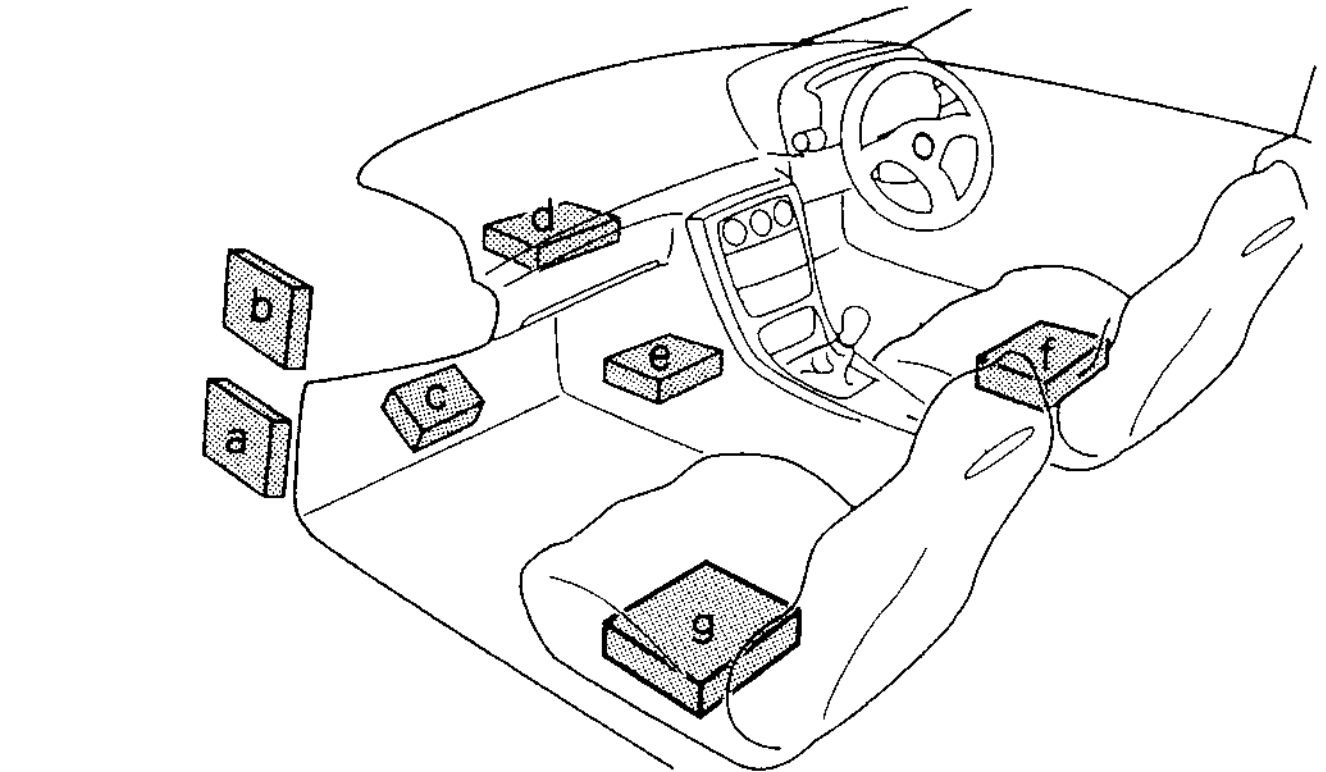

*This Arrangement of ECU is for only Right Handle Car.

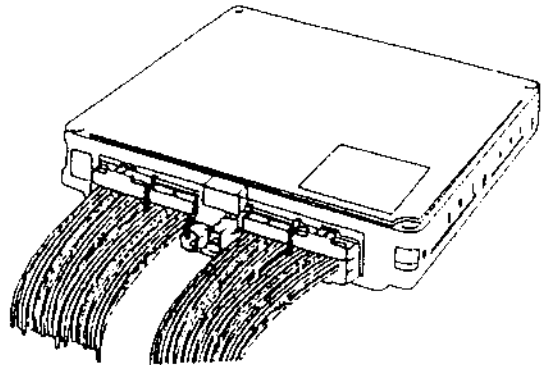
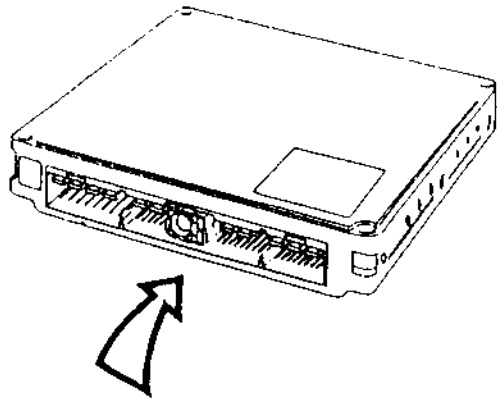

*The Following Diagrams View the Coupler from the Same Angle as the Diagram.
Please be Careful Not to make Improper Connections or Short Out the Unit.

8

Vehicle Specific ECU Wiring Diagram

8.1 NISSAN

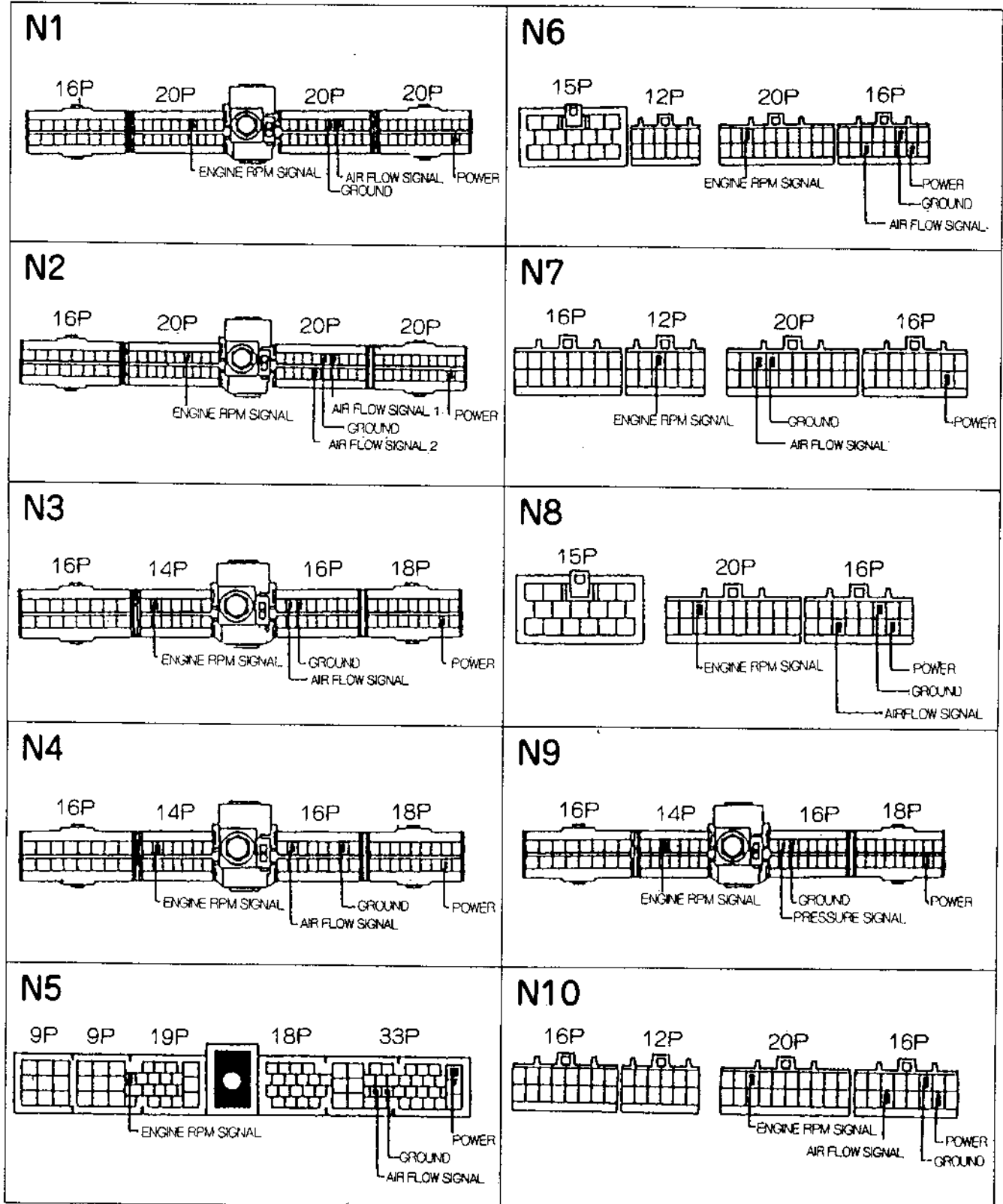

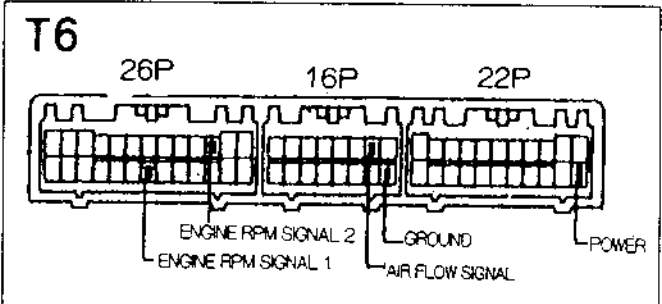
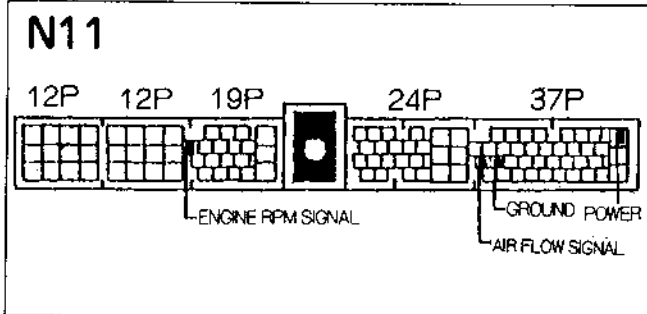

8.2 TOYOTA

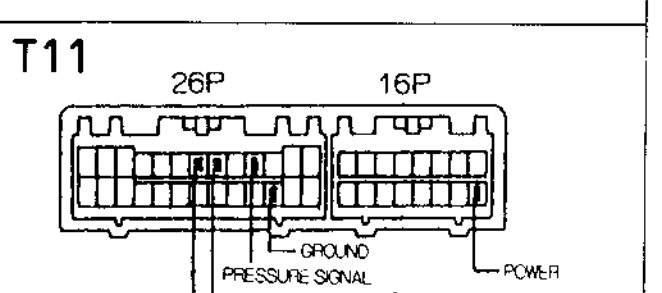
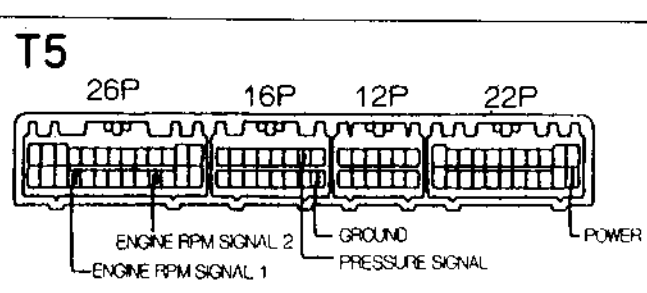
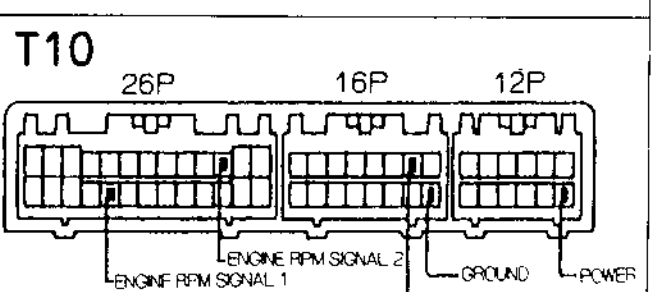
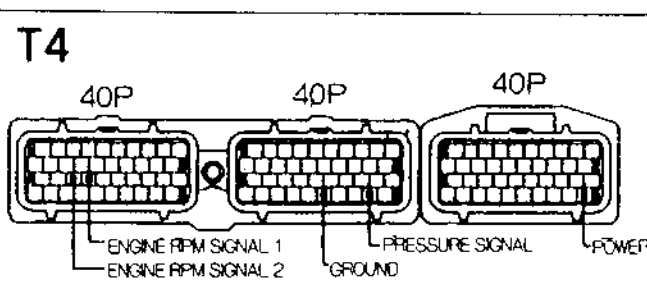
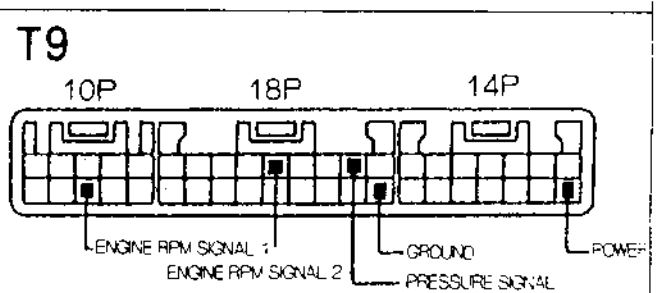
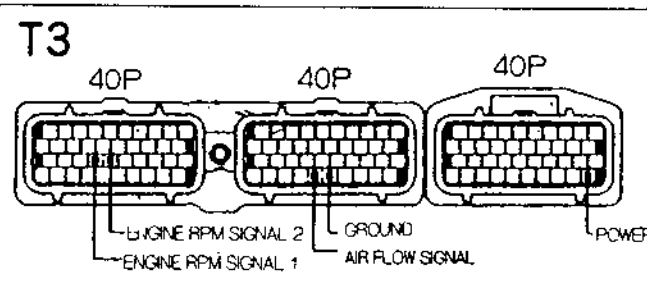
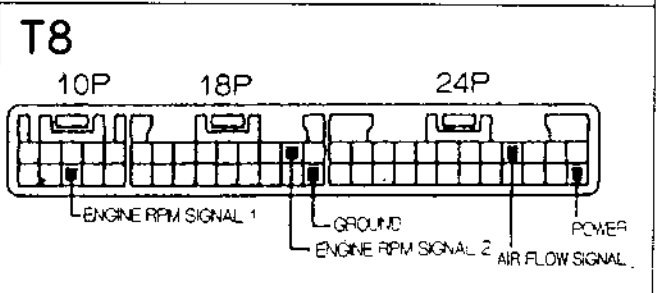
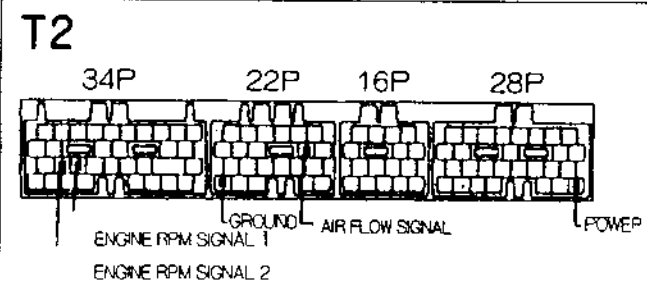
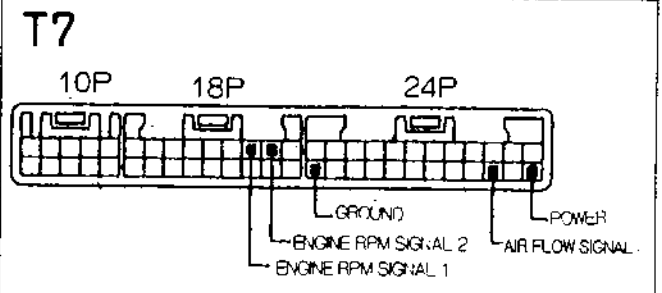
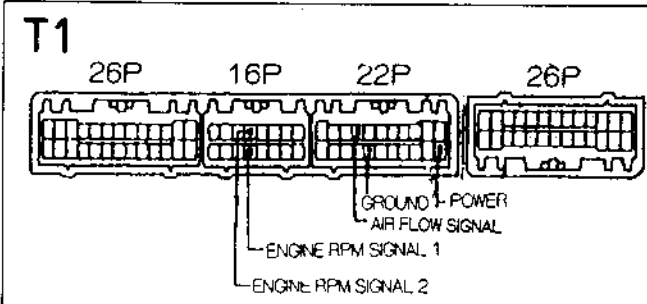

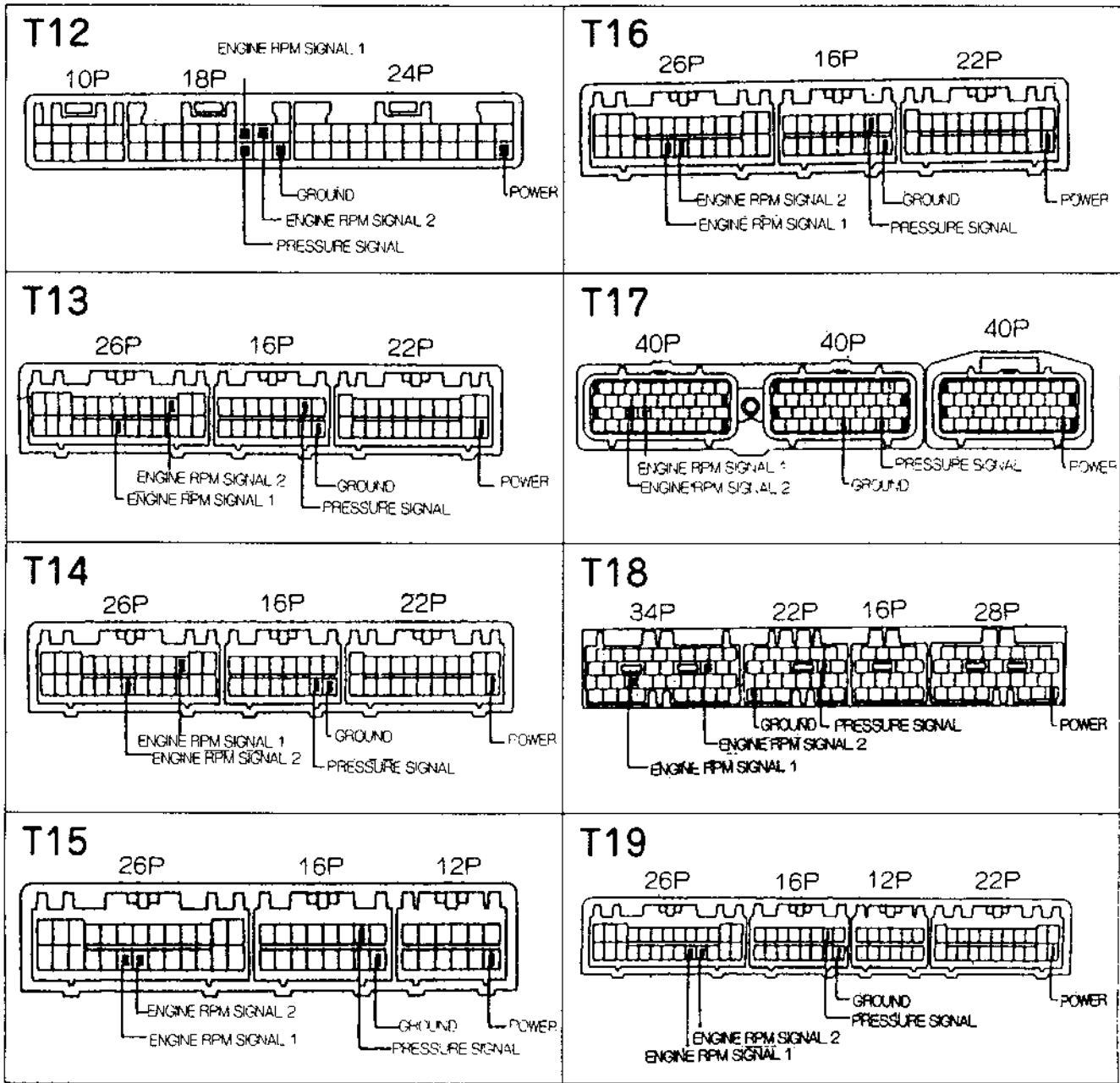

*The regular connection is to engine RPM signal 1.
 In the case of the plural connection, connect to engine RPM signal 2.

8.3 MITSUBISHI

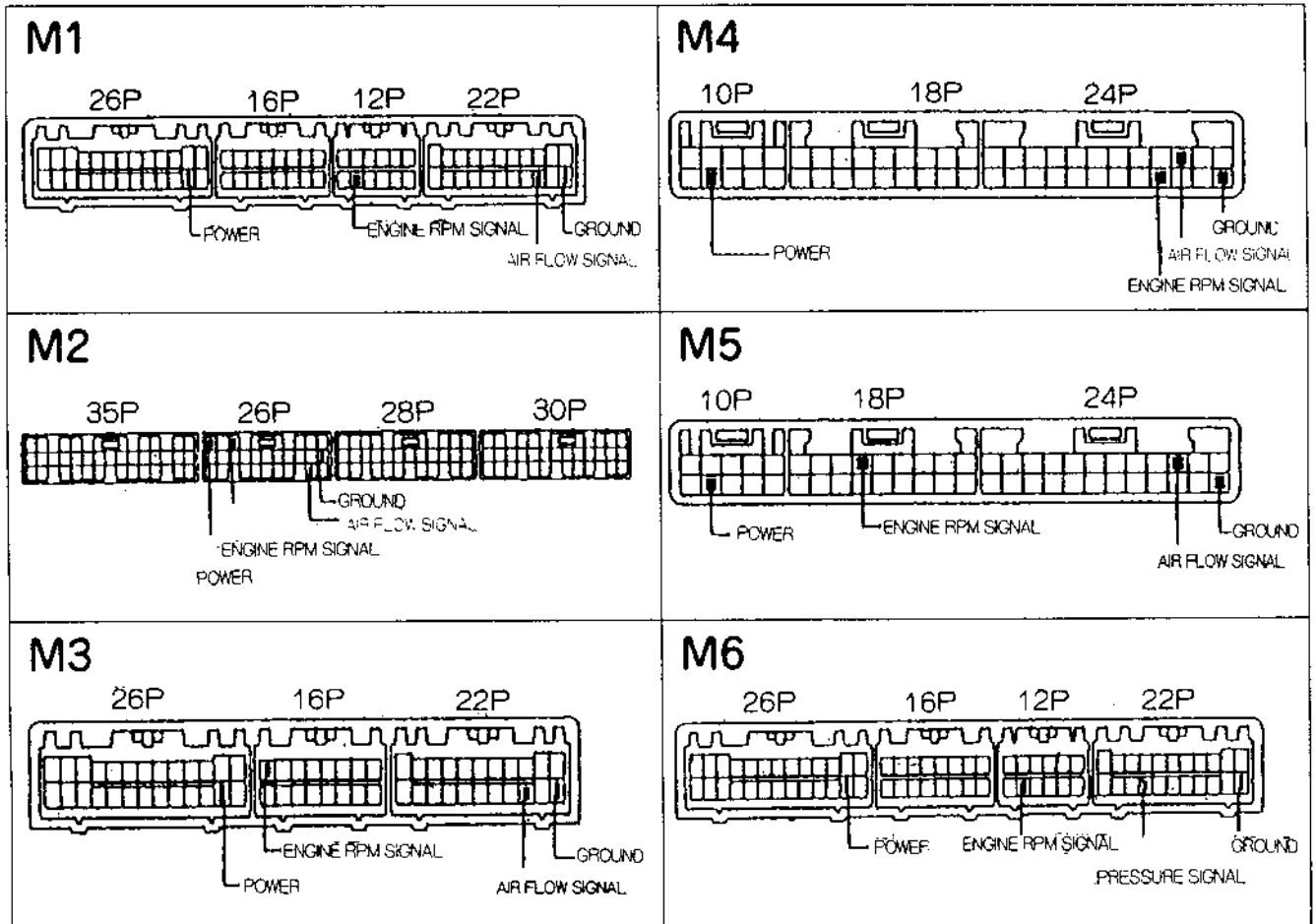

8.4 HONDA

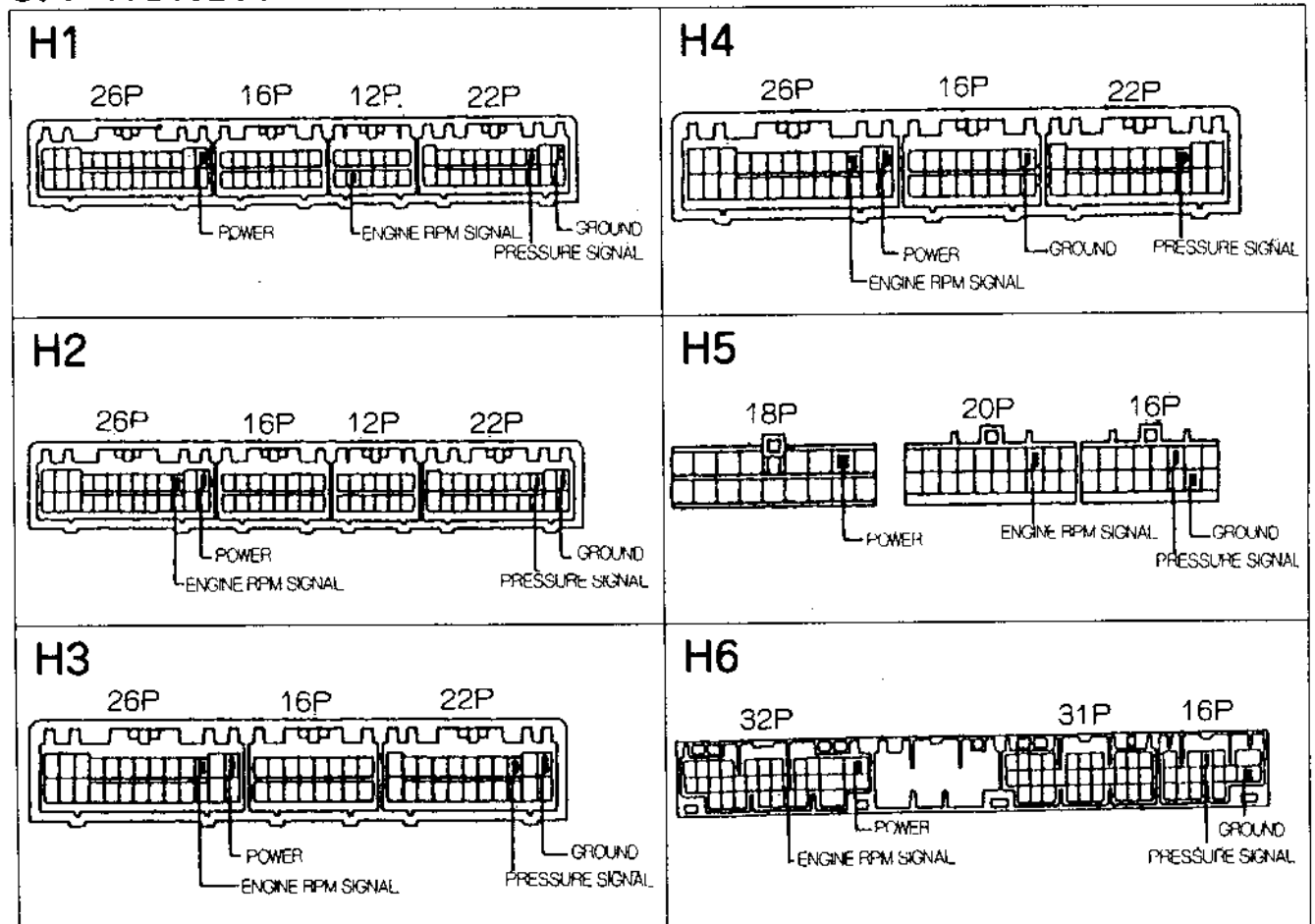

8.5 MAZDA

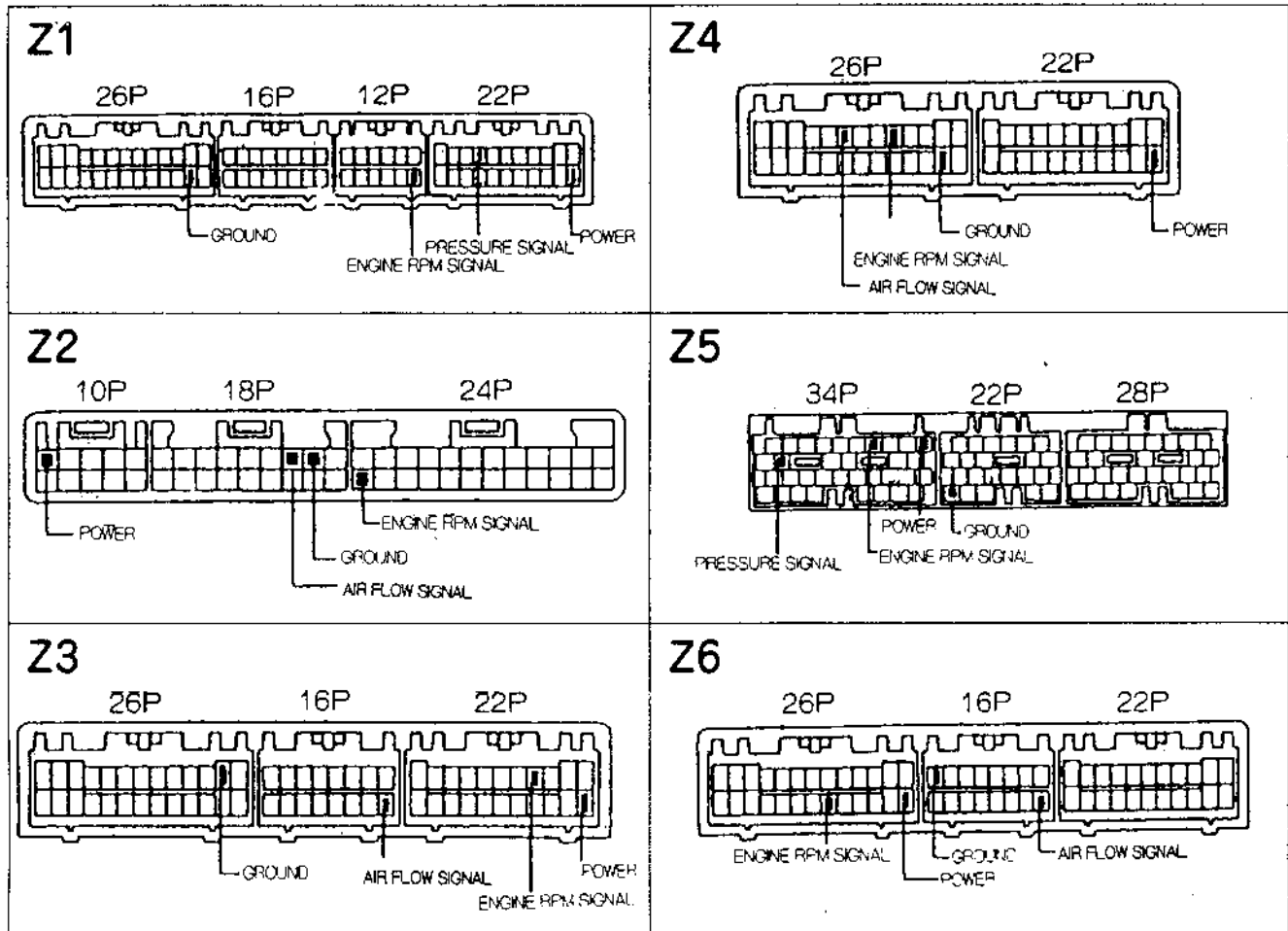

8.6 SUBARU

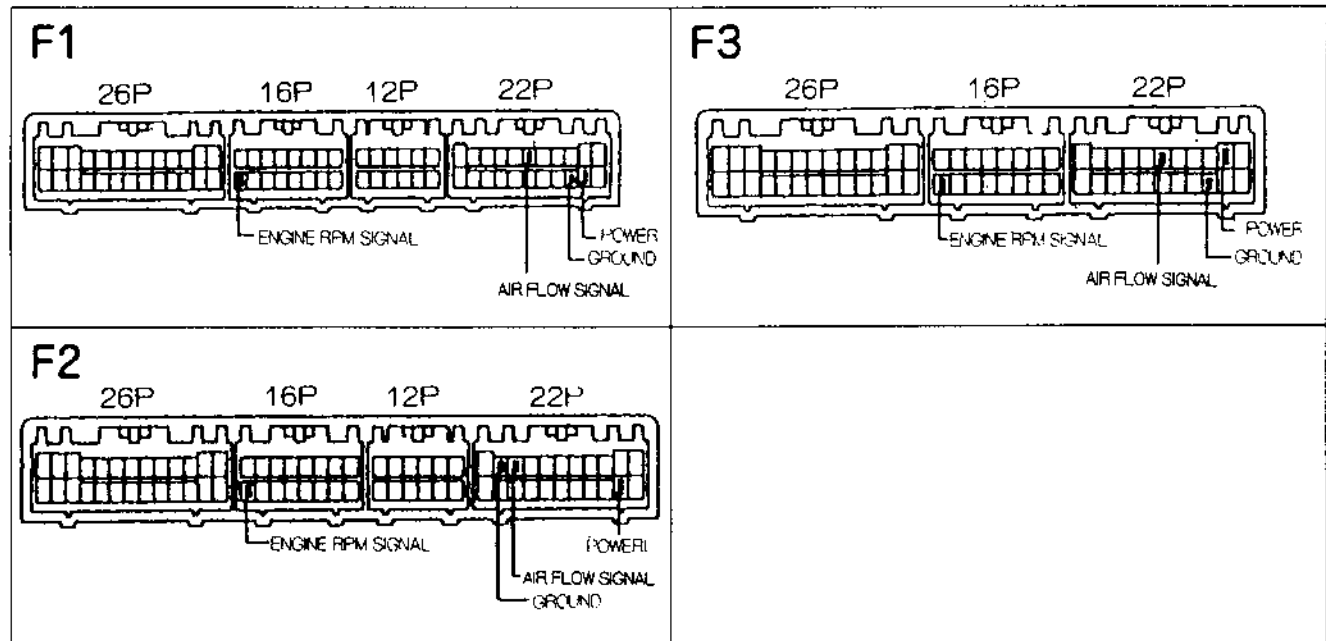

8.7 ISUZU

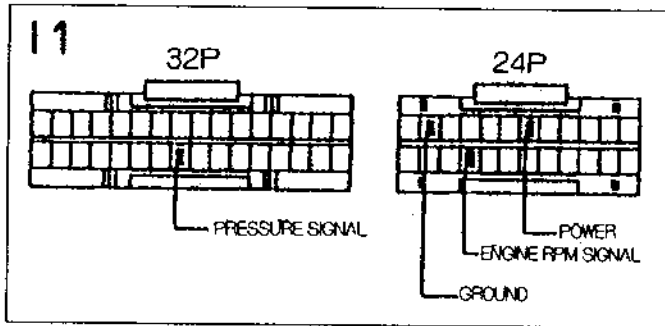

8.8 SUZUKI

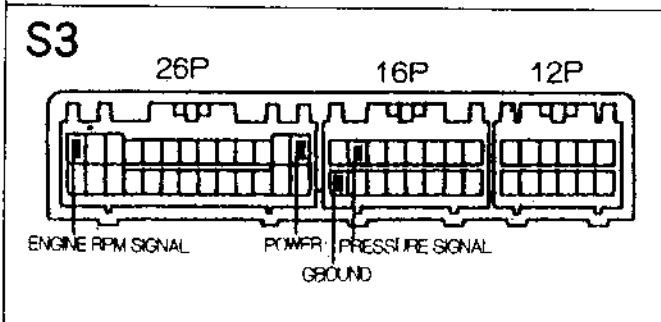
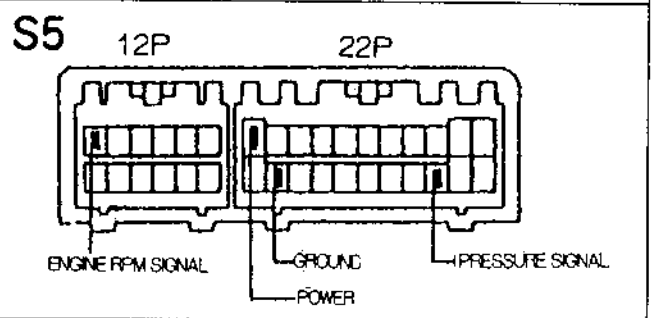
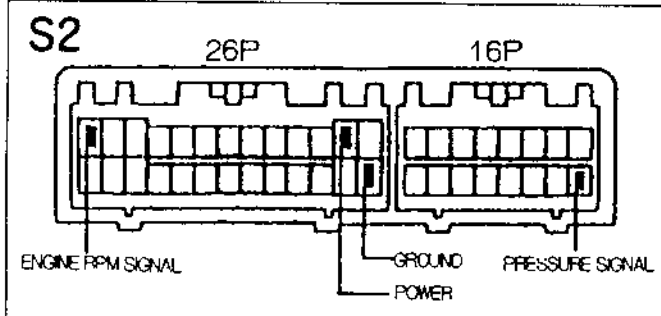
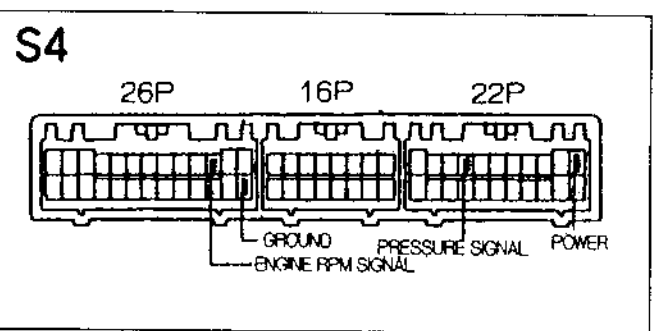
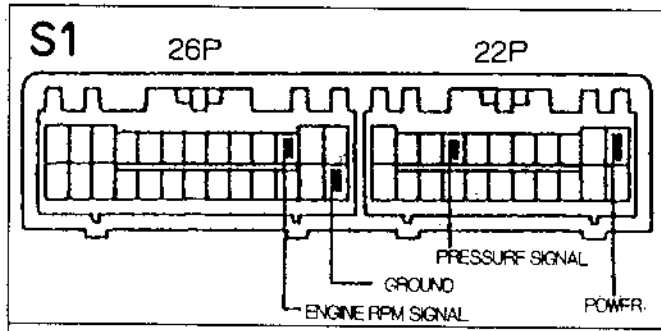

8.9 DAIHATSU

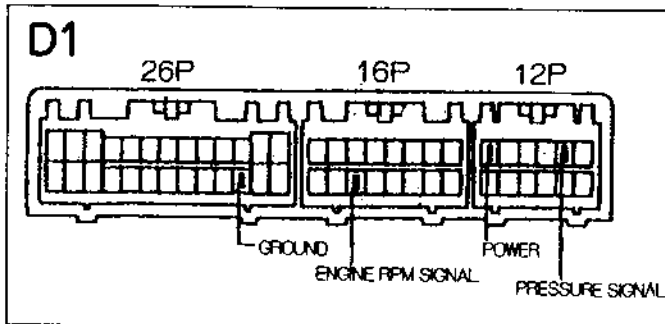

8 Connection Diagram for S-AFC and Other Equipment S-AFC-FI MANAGE-BFC-POWER METER Connection Diagram

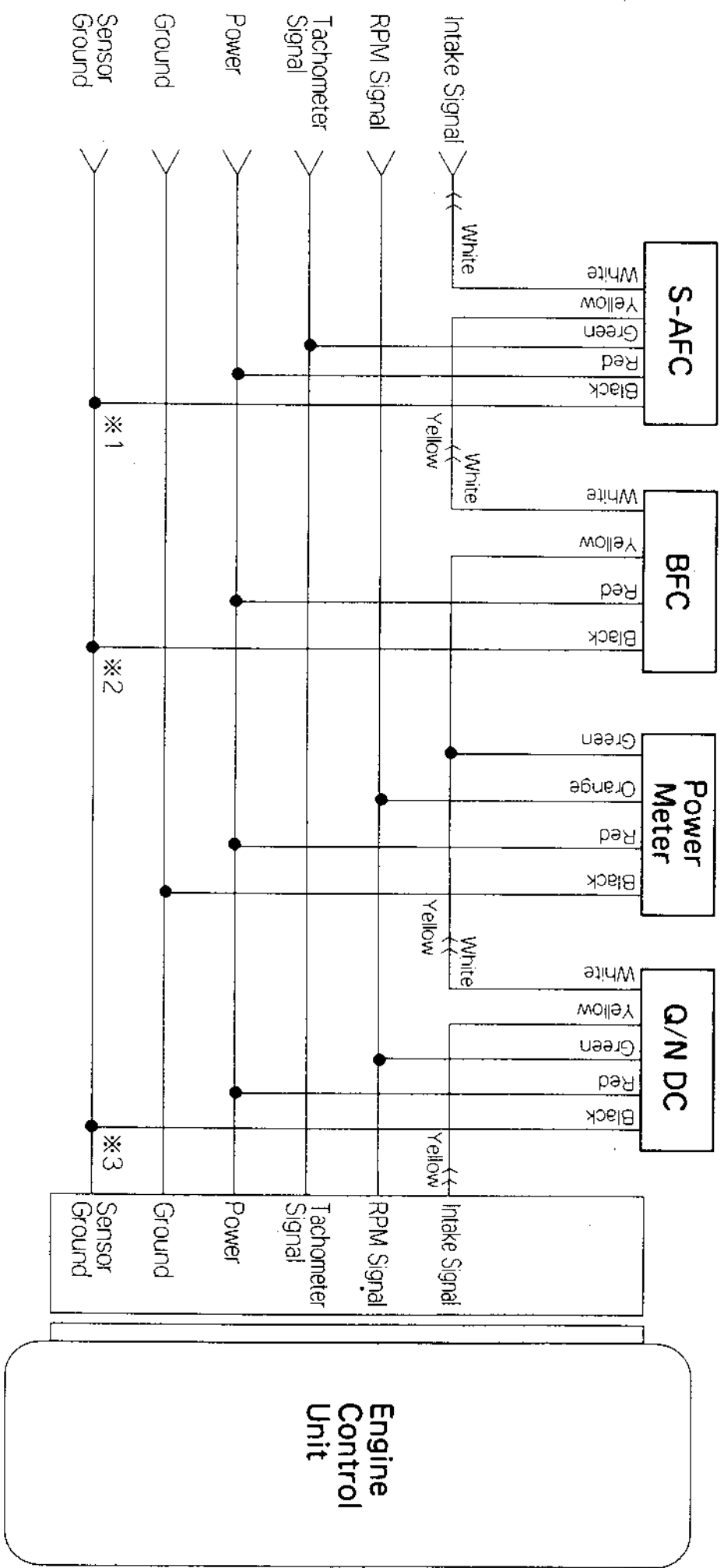

- *1 Be sure not to ground the S-AFC ground to the power ground but to the sensor ground specified in the instruction manual.
- *2 Be sure not to ground the BFC ground to the power ground but to the sensor ground specified in the instruction manual.
- *3 Be sure not to ground the Q/N DC ground to the power ground but to the sensor ground specified in the instruction manual.

S-AFC-FI MANAGE-BFC-POWER METER Connection Diagram (GT-R)

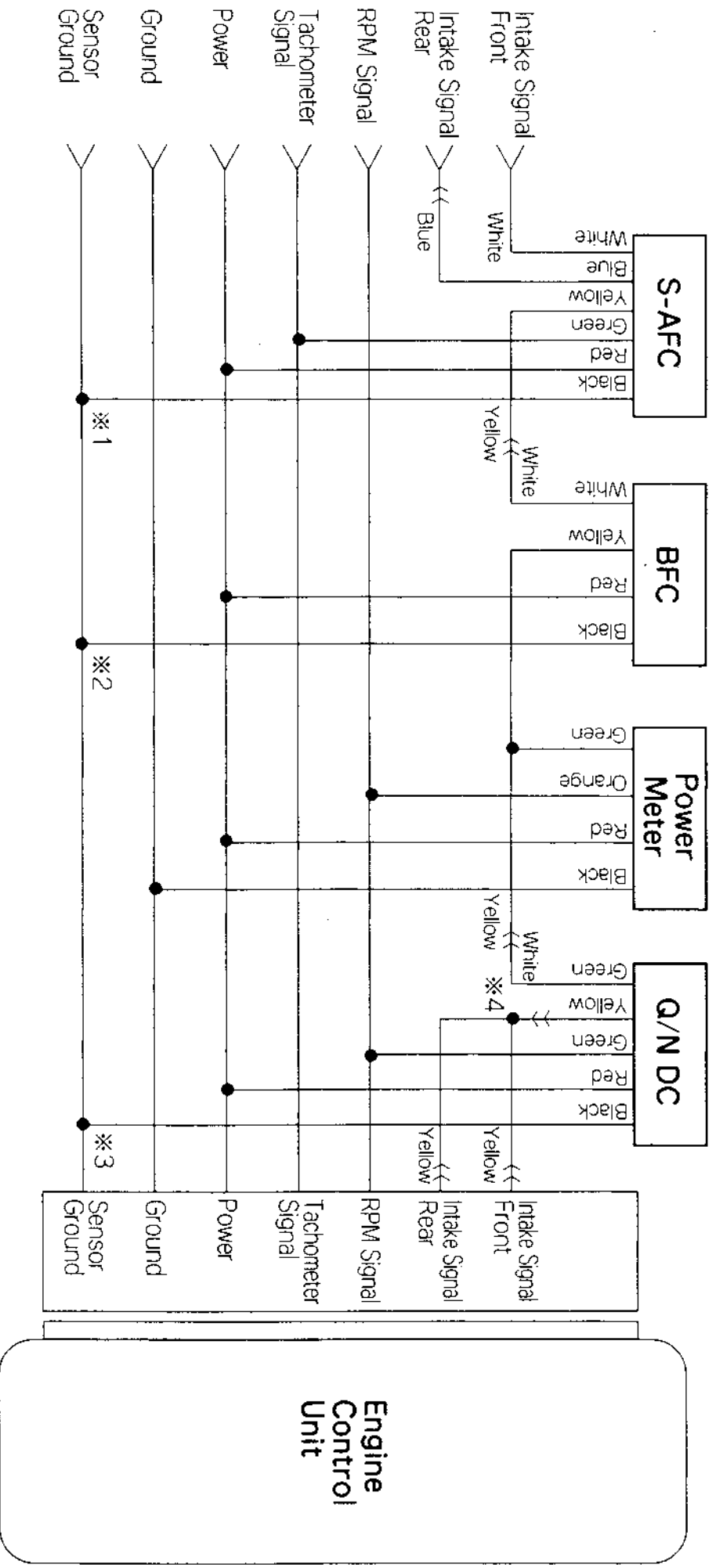

- *1 Be sure not to ground the S-AFC ground to the power ground but to the sensor ground specified in the instruction manual.
- *2 Be sure not to ground the BFC ground to the power ground but to the sensor ground specified in the instruction manual.
- *3 Be sure not to ground the Q/N DC ground to the power ground but to the sensor ground specified in the instruction manual.
- *4 Use the included S-AFC splitting adapter harness.

Vehicle Specific Setting Table with Using BFC & Super AFC.

The Case of Using VH 45 Air Flow Meter(90Φ)

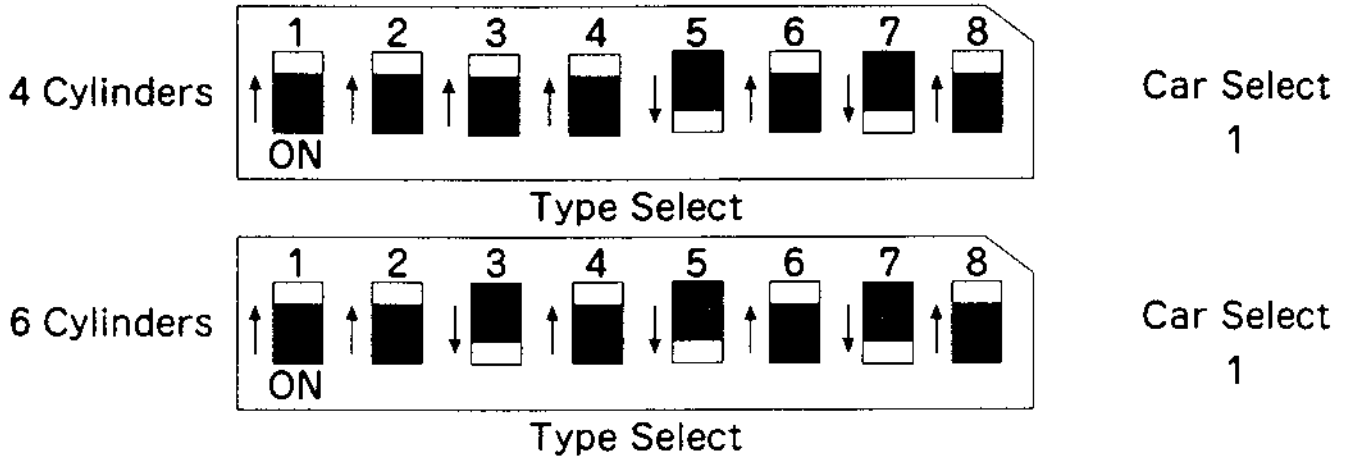

The Case of Using DENSO Pressur Signal

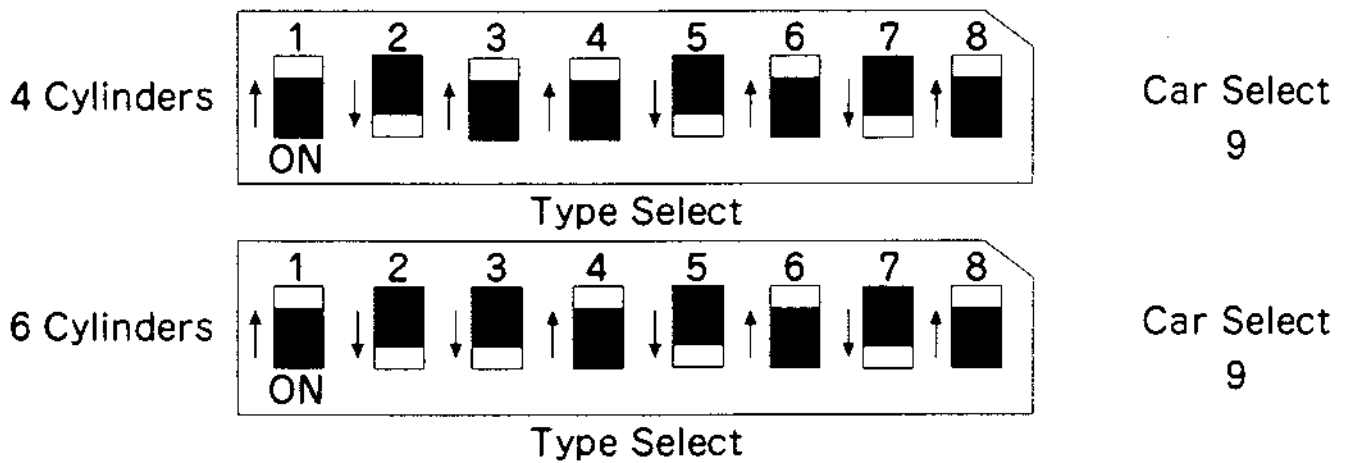

GTR The Case of Using Air Flow Meter for R32.

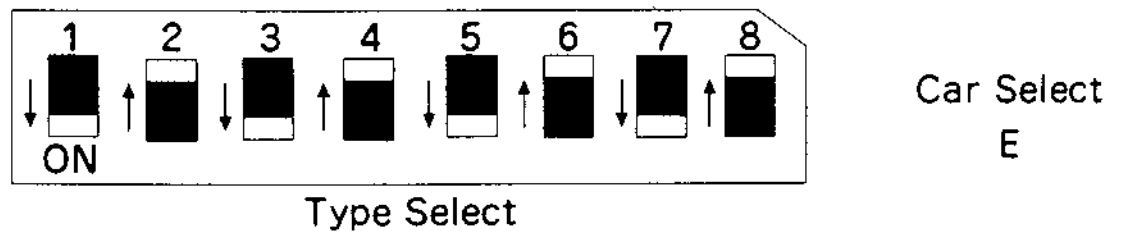

GTR The Case of Using Air Flow Meter for Z32.

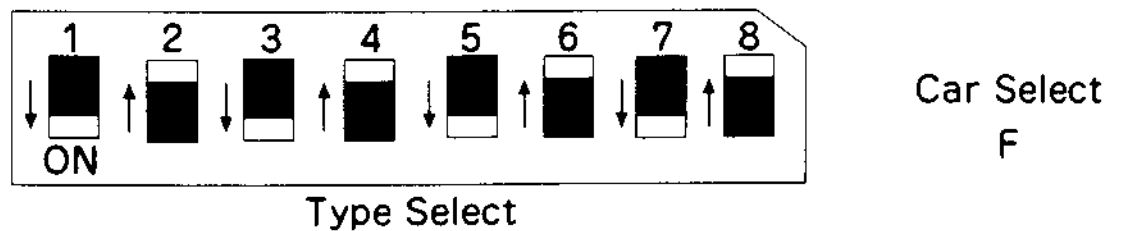

※Please move the switch towards the white colored section.

***Warnings**

- Please have all setting procedures done at an experienced A'PEX dealer.
- Some vehicles may experience a fuel cut if the volume is turned too much to the + side.
- Please be aware that on vehicles with small air flow meter volumes, turning the volume knob to the + side past the limits of the air flow meter will not produce any changes in the fuel mixture.
- Please be aware that the engine control unit on some vehicles may limit the maximum amounts of injected fuel according to RPM. Turning the volume knob to the + side past these limits will not produce any changes in the fuel mixture.
- Be sure that the Air flow type selection switch and the vehicle selection switch on the rear panel have been set correctly. Incorrect settings may lead to engine failure. Please refer to the vehicle specific charts to determine the correct settings for the vehicle application.
- Please mount the unit away from direct sunlight.
- Please do not adjust the vehicle selection switch while the engine is running.

! DANGER

- If driving becomes a necessity for setting purposes, be sure never to be an obstruction to traffic and follow all the rules of the highway.
- Never adjust the knobs on the controller unit while driving as it is extremely dangerous.

! CAUTION

- Improper settings may lead to engine failure. Please perform setting procedures with caution.
 - Be sure to pay close attention for knocking noises and to exhaust temperatures when setting the adjustment volumes.
 - Never disassemble this product.
 - If any unusual engine characteristics arise during use of this unit, discontinue use immediately and contact our office.
- *Product pricing, hardware, functions and other aspects may change without notice.**
- *It is necessary to follow all road and highway regulations at all times.**



APEX
APEX CO., Ltd. JAPAN